

USE AND MAINTENANCE
USO E MANUTENZIONE
UTILISATION ET ENTRETIEN
BETRIEB UND WARTUNG
USOY MANTENIMIENTO

AUTOMOTIVE ENGINES

N SERIES

CNG



Publication edited by
Marketing - Adv. & Promotion
Print L31900089 - 05/10

N SERIES

N60 ENT G

USE AND MAINTENANCE

INTRODUCTION

We would like to thank you for buying an FPT product, and compliment you on your choice of engine.

Before you carry out any operation involving the engine or its fittings, please read the contents of this manual carefully; compliance with the instructions provided in the manual is the best way to guarantee trouble-free, long term operation of the engine.

The contents of this manual refer to the standard configuration of the engine, and the illustrations are purely indicative. Some instructions are provided by giving the sequence of operations to be carried out in order to allow the engine and/or its fittings to perform in a certain way. In some cases they will be dependent on the configuration of the commands and the set-up of the vehicle on which the engine is installed; for any points that differ from the contents of this manual, please consult the instructions provided by the vehicle Manufacturer or a specific manual.

The information provided below was current at the date of publication.

The Manufacturer reserves the right to make modifications at any time without prior notice, for technical or commercial reasons or to update the engines to comply with legal requirements in the various Countries.

The Manufacturer declines all liability for any errors or omissions.

Please remember that the FPT Technical Service Network is available to offer you its experience and professional skills, wherever you may be.

TABLE OF CONTENTS	Page
■ GENERAL INFORMATION	3
Guarantee	3
Spare parts	3
Liability	3
Safety	3
N60 ENT G engine technical data	4
Labels	6
■ USE	7
Refuelling	7
Preliminary checks	8
Starting and stopping the engine	9
Idle speed and cruise speed management - PTO/cruise control ..	12
Engine speed speed management - PTO/Tempostat®	14
For proper use of the engine	15
Special warnings	15
Running-in	19
Refilling	20
■ INSPECTIONS AND MAINTENANCE	21
Maintenance personnel	21
Accident prevention	21
Frequency	22
How to	24
Moving the engine	33
Disposal of waste	33
■ LONG ENGINE INACTIVITY	34
Preparing the engine for a long period of inactivity	34
Restarting the engine after a long period of inactivity	35
■ ENGINE MALFUNCTIONS	36
■ BEHAVIOUR IN AN EMERGENCY	37

TABLE OF CONTENTS	Page
■ APPENDIX	40
Procedure for system emptying	40
System tightness test	41
Oil viscosity compared to ambient temperatures	42

■ GENERAL INFORMATION

GUARANTEE

In order to ensure that your engine gives the best possible performance and to take advantage of the FPT guarantee, you must follow the indications provided in this publication with great care; failure to do so may result in invalidation of the guarantee.

SPARE PARTS

Always use Original FPT Spare parts. This is essential to keep the engine in original running order.

The use of non-original spare parts will not only invalidate the guarantee, but will mean that FPT will not be considered liable in any way during the whole working life of the engine.

LIABILITY

The Manufacturer will only be considered liable subject to performance of the control and maintenance operations indicated and described in this manual; to this effect, proof that these operations have been performed must be provided. Any special maintenance operations that may be necessary must be carried out by qualified technicians from FPT Network or other specialised workshops, using the instruments and equipment provided for the purpose.

SAFETY

The following information is intended to encourage caution when using the engine, so as to avoid damage to persons or property as a result of improper or incorrect behaviour.

- ❑ The engines must only be used for the purposes indicated by the Manufacturer.
- ❑ Any tampering, modification and use of non-original spare parts may compromise proper operation and safe use of the engine; never, **under any circumstances make modifications** to the wiring and to the units equipping the engine, or connect them to other power systems.
- ❑ Pay particular attention to moving parts of the engine, to high temperature components and to circuits containing pressurised fluids; its electrical equipment houses electrical currents and voltage.
- ❑ Engine exhaust gases can be dangerous for health.
- ❑ The operations required to guarantee the best possible use and preservation of the engine must only be carried out by persons of proven experience, equipped with tools considered suitable by FPT approved staff.

All directions related to safety of personnel and safeguard of engine are contained in the sections on USE and INSPECTIONS AND MAINTENANCE.

WARNING!

The use of gaseous fuel requires strict compliance of the standards and directions contained in this document.

N60 ENT G ENGINE TECHNICAL DATA

The technical code and serial number are indicated on a plate, which is located on different parts of the engine, according to the model: flywheel casing, tappet cover, other.

Code	N60 ENT G
Engine family	F4B
Cycle	Otto, 4-Stroke
Number and arrangement of cylinders	6, in line
Bore x Stroke	102 x 120 mm
Total displacement	5,880 cm ³
Air supply	Supercharged and Aftercooled
Injection type	Multipoint, timed
Firing type	Single coil spark
Engine rotation direction	Counter-clockwise (seen from flywheel side)
Dry weight	520 kg
Electrical system	24 V (rated)
Alternator	24 V - 90 A
Starter motor	24 V - 4.5 kW

Performance (*)

N60 ENT G

EEO limits	147 kW (200 HP) @ 2,700 rpm 650 Nm (65 Kgm) @ 1,250 rpm
------------	--

(*)Net performance at flywheel in compliance to EC Directive 97/68 (without fan), after 50 hours operation - Tolerance 3% - Fuel: CNG - G25.

Test conditions: temperature: 25 °C, atmospheric pressure: 100 kPa, relative humidity: 30%. ISO Standard 3046/1, applicable to DIN 6271, BS 5514, SAE J 1349 Standards.

WARNING!

Any deviations from the test conditions mentioned above, and any modification of the data saved in the electronic units of the injection and ignition system and of the characteristics of the engine and its equipment, are strictly forbidden and cause the loss of the warranty and of any FPT responsibilities.

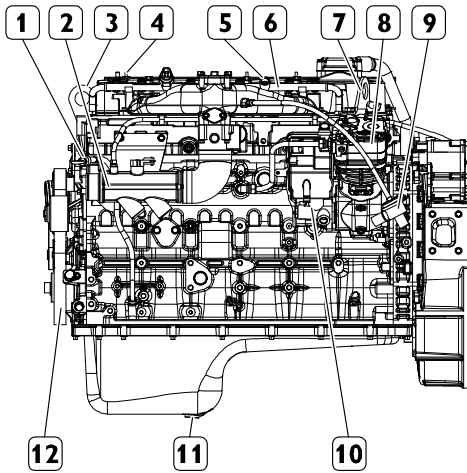

10 008 N

N60 ENT G

1. Oil level dipstick - 2. Engine air intake - 3. Lifting eyebolt - 4. Oil filler cap - 5. Fuel inlet coupling to fuel sender - 6. Fuel sender - 7. Lifting eyebolt - 8. Auxiliary air compressor (opt.) - 9. Boost air recirculation air valve - 10. hydraulic pump - 11. Oil drain plug - 12. Accessory drive belt.

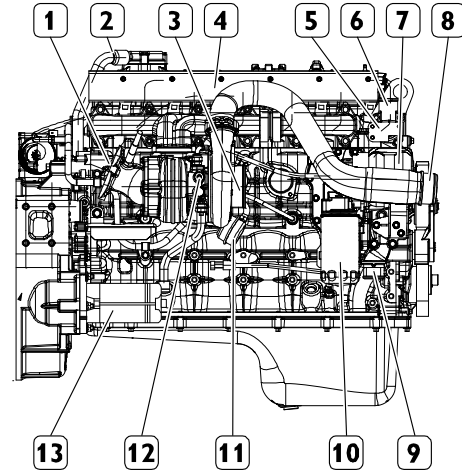

10 009 N

N60 ENT G

1. Exhaust gas outlet from supercharger - 2. Oil vapor bleed - 3. Filter air intake - 4. Boost air outlet from supercharger - 5. Ignition coil position - 6. Coolant outlet from thermostat to transmission oil heat exchanger - 7. Thermostat position - 8. Alternator - 9. Fluid inlet from engine coolant heat exchanger - 10. Lubricating oil filter - 11. Wastegate air actuator - 12. High temperature fluid outlet for fuel pressure reducer warm-up - 13. Starter motor.

LABELS

On the engine or on its parts, warnings may be available. The meaning is illustrated hereunder.

Note: The indications with an exclamation mark highlight a potential danger.



Lifting point (engine only).



**Fuel refill plug
(on tank, if available).**



Lubricant refill plug.



Lubricating oil dip-stick.



**Burn hazard:
Pressurised hot water expulsion.**



**Burn hazard:
High temperature parts.**



**Fire hazard:
Fuel presence.**

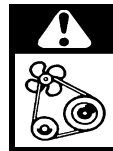

**Hazard of collision and contact
with moving parts:
Presence of fans, pulleys, belts or other.**

■ USE

REFUELLING

Use only fuels compliant to the applicable International standards in force.

Preserve storage tanks from possible contamination and provide regular maintenance of fuel delivery systems.

The use of non-compliant fuel will cause the loss of all FPT responsibilities resulting from operating failures and damages.

CAUTION!



The first fuel filling can be made only after sealing test has been passed successfully.

Tanks are filled with pressurized fuel at 200 bar (20 MPa) and small amounts of gas can be released during this operation as evidenced by the typical smell of the substance (THT) that is added to this purpose to the natural gas (THT). During this operation, wear suitable safety gloves to protect the skin from freezing when exposed to quick decompression of the released gas.

Safety directions for refueling operations

Prevent access to the dangerous area

Prevent any movement of the vehicle to be refueled with wheel clamps.

When in the refueling area, put out the engine.

Make sure that suitable fire extinguishers (class C) and other fire prevention devices are available on site

Do not smoke or handle open flames or high temperature heat sources.

Inspect tanks before refueling for any evident defects.

Immediately interrupt gas delivery in case of manifest leakage.

Prevent any dispersion into the atmosphere of the fuel contained in the tanks or hoses.

CAUTION!



Failure to keep fuel leakage under control causes the RISK OF EXPLOSION.

WARNING!

Do not use bottles that have been involved in crash or fire or showing evident defects.

Directions for refueling

Under normal conditions, fuel pressure in tanks should not exceed 220 bar (22 MPa), when referred to a max temperature of 65 °C (338 K) and the fuel delivery pressure should not exceed 260 bar (26 MPa).

Max temperature in the tanks should not be over 65°C (338 K) excepting some short transitory peaks during refueling.

Procedure

1. Stop the engine and the auxiliary heater and pull the key from ignition switch.
2. Check that shutoff valves on the tanks are open.
3. Close general shutoff valve. This operation can be skipped when the filler pipe is provided with check valve.
4. Connect and fasten filler pipe.
5. Open general shutoff valve.
6. Open the valve on the hose and wait until the system is full, the pump is usually fitted with an automatic system to cut off fuel delivery as the maximum pressure is reached.
7. Close general shutoff valve.
8. Close the valve on the hose to empty the hose. Act with caution
9. Disconnect filler pipe.

PRELIMINARY CHECKS

Before each engine start-up:

- Check and refill technical fluids level if necessary (fuel, engine oil and coolant).
- Make sure that the air aspiration filter is not clogged or obstructed. If the engine is equipped with an electrical blockage sensor, an alarm will be displayed on start-up by means of the indicator light on the instrument panel.
- Check that fuel pressure in the tank is above 20 bar (2 MPa) , i.e. the minimum value allowed.
- Check that shutoff valves on tanks are open and that any other fuel flow shutoff system are set to enable start up.
- Inspect for any fuel leakage.

CAUTION!



For fuel pressure below 20 bar (2 MPa) accurate fuel metering is not ensured and the catalytic converter might be damaged. If refueling at higher pressure cannot be made, keep engine running idle.

WARNING!

Any outflow limiting valves might cause incorrect indication of tank level.

Note: the current document refers only to the standard engine configuration and does not contain any explanation related to the checks of the power train parts and components installed on the engine. Refer to the corresponding documentation of the manufacturer for any information about those systems.

CAUTION!

Make sure that no combustible vapours or gasses are present in the area in which the engine is to operate. Ensure that closed areas are adequately ventilated and fitted with a suitable exhaust extraction system.

STARTING AND STOPPING THE ENGINE

Start and stop procedures described below assume the presence of the ignition key switch typically installed on vehicle; if the manufacturer of the means has built a customized instrument panel, these procedures can change according to the different characteristics chosen by the manufacture.

In these cases, follow the start-up/shut-down sequences and use the instrument panel description provided in the specific documentation. If the means is provided with safety system preventing engine start or the movement of the means without suitable safety measures, make sure that the conditions for use are met.

Starting the engine

1. Insert the key into the switch (1) and turn it to the right to position **1B** RUN. Once the indicator lights have been tested, check the plausibility of the indications on the dashboard.
2. Turn the key to position **1C** START and release it once the engine has started, without accelerating.
3. In the event that the efficiency indicators such as the “Accumulator recharge” or “Oil pressure” are available on the on-board equipment, check that the operation status is appropriate.
4. If the engine does not start, after releasing the key it will only be possible to turn it back to the start position after first returning the switch to the rest position **1A**.

Detail of the key switch

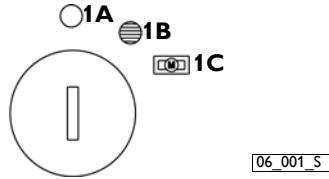

- 1A** REST position allowing the key to be removed
- 1B** Stable RUN position
- 1C** Unstable START position

For safety reason, the engine electronic control unit turns shutoff valves off after a delay of few seconds from setting the ignition switch to RUN.

If start does not occur within this time, the ignition switch must be turned back to OFF and the start up operation must be repeated after a given time interval.

Stopping the engine

Before stopping the engine it is recommended to keep it running at idle and unloaded for a few minutes; this will allow a uniform decrease of temperature and avoid harmful thermal shocks.

Shutting down the engine:

- Turn the key switch to position **1A** REST.

Note: Once the switch is OFF, the engine electronic control unit turns the general supply relays off after a delay of few seconds to enable self-adaptivity data learning.

WARNING!

*The electrical main switch must be open only after a time delay of more than 15 seconds from engine shutoff to enable the completion of the auto-adaptivity data learning procedure.
Failure of this, correct system operation is not guaranteed with consequent risk of damage to system components.*

Restarting the engine:

1. Return the key switch from the position **1A** to position **1B** only after a few minutes.
2. Turn the key to position **1C** START and release it once the engine has started, without accelerating.
3. Proceed as described previously.

Starting the engine at low temperatures

Engine start is guaranteed up to temperature of 253 K (-20°C). When a pre-heating system is installed for operation at lower temperature, follow the startup procedure indicated by the means manufacturer or fitter.

Failure indicator lamp

If one or multiple indicator lamps remain illuminated after startup, follow the instructions contained in SPECIAL WARNINGS or apply to a Technical Service center for assistance. Some failures detected by the engine electronic control unit do not stop vehicle operation although some simple directions must be followed.

(For more information see the section ENGINE MALFUNCTIONS).

CAUTION!



In the event of momentary stoppages of the engine, check for any alarm signals. Do not restart the engine until the cause of the problem has been removed or proper operating conditions have been restored.

Parking

WARNING!

If the engine is not going to be restarted for a prolonged time, close manual shutoff valves in the supply system.

Starting from engine compartment

Some vehicles can carry out the starting and stopping procedure by means of push-buttons located in the engine compartment. The modality for using them may vary according to the choices realized by the vehicle manufacturer.

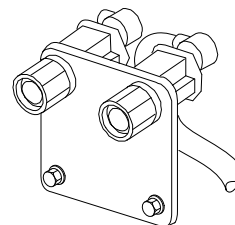

06_013_N

WARNING!

Engine startup from push-buttons requires observance of the safety directions for the safeguard of persons and equipment. Install wheel clamps to prevent any accidental movement of the vehicle.

Speed limiter (if equipped)

Engine electronic control units feature max speed limiter as prescribed by the legal requirements in force in some countries. The limit speed, i.e. the speed at which the operation of the accelerator pedal no longer affect vehicle speed, is set by the Technical Service and cannot be modified during use.

When implemented, this function starts automatically and cannot be overridden.

Some engine electronic control units are preset for speed limiting function as prescribed by the safety regulations associated to the mission of the means or vehicle. These parameters are set in the engine control unit like those described above.

If implemented, the function of limit 2 or limit 3 is started automatically or by operation of the associated control.
(Further details can be provided to the Fitter).

Accelerator override (if implemented)

The purpose of this function is to prevent the vehicle or means from starting when some specific dangerous conditions are present, as it may happen with a bust starting with doors or tailgates open.

When implemented, this function is automatically started by the safety control.

As normal conditions are restored, the electronic control unit commands gradual increase of throttle opening angle and consequent acceleration to the speed required by the driver.

IDLE SPEED AND CRUISE SPEED MANAGEMENT - PTO/CRUISE CONTROL (if implemented)

Some vehicles are equipped with optional controls through which they manage the engine rpm or the vehicle speed. Management is done manually by using the push-buttons located near the steering wheel or another suitable position; here are their functions:

- ON+** Increase rpm or speed (1)
- ON -** Decrease rpm or speed (2)
- RESUME** Save a new data or recall the last data setting (3)
- OFF** Disable the function currently active (4)

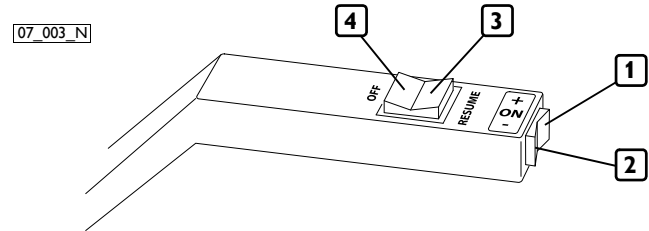

- The figure is relevant to an FPT component -

Engine speed setting with the POWER TAKE-OFF engaged (if foreseen)

The procedure described here below will become effective only if the temperature of the engine exceeds 30 °C and the vehicle is parked.

1. Start the engine and wait until the pre-set idle speed stabilizes itself.
2. Enable the PTO following the instructions illustrated in the relevant documentation.
3. Press the brake pedal.
4. Make sure that FAIL telltale is off.
5. Act on the ON + or ON – buttons to adjust the speed at the desired value or press the RESUME button for 1 second to recall the value previously set.
6. Press the RESUME button for about 5 seconds to save the new value.
7. Before releasing the brake pedal, check that the parking brake is engaged.

Engine idle speed setting for use of PTO (if implemented)

The CRUISE CONTROL function allows to set/modify the vehicle speed without using the accelerator pedal.

The CRUISE CONTROL should not be used under heavy traffic conditions or on roads where the driver must have a constant control on the vehicle speed.

The function is active only if the following conditions are met:

- Vehicle speed exceeding 30 km/h;
- The brake pedal has been pressed at least once;

- Brake pedal not operated;
- Clutch pedal not operated;
- Transmission ratio not engaged;
- Slowdown brakes not operated.

ON + button:

- Pressed only once, it allows the release of the accelerator pedal and to retain the speed achieved at that moment by the vehicle.
- Kept pressed, after the first time, it allows to increase the speed of the vehicle without intervening on the accelerator pedal.

ON - button:

- Pressed after the ON + button it allows to decrease the speed of the vehicle.

RESUME button:

- Pressed while driving, it recalls the last saved speed value setting. The vehicle will achieve the set speed depending on the selected transmission gear.

OFF button:

- It disengages the CRUISE CONTROL function.

Disabling the CRUISE CONTROL

The function is automatically disabled in the following cases:

- When the maximum allowed rate is reached.
- By actuating the brake pedal (permanent disengagement).
- By actuating the clutch pedal.
- By operating the slowdown brake (if foreseen).
- When the minimum engagement speed is reached.
- By actuating the accelerator pedal to reach a higher speed with respect to the set one:
 - a) If the action lasts less than 3 minutes, the function temporarily disengages and when the pedal is released the Electronic Unit takes the vehicle back to the speed previously set;
 - b) If the action lasts more than 3 minutes, the CRUISE CONTROL function is permanently disengaged.

ENGINE SPEED MANAGEMENT - TEMPOSTAT® (if implemented)

The Tempostat® function enables a constant engine speed or vehicle speed without operating the acceleration pedal.

Engine idle speed setting for use of PTO

The electronic control unit controls constant engine speed regardless of any sudden power torque intake or variable torque requirement.

With stationary vehicle (speed below 7.5 km/h) and engine running, operate the accelerator pedal and bring the engine speed to the desired rpm, then switch the Tempostat® control lever.

Bring control lever back to home position to slow engine speed to idle.

As the electrical control unit reads a speed over 7.5 Km/h, the control is turned off and the engine returns to idle speed.

FOR PROPER USE OF THE ENGINE

- ❑ Do not leave the key turned to the start position **1C**, when the engine has been started.
- ❑ It is not efficient to leave the engine running at idle while waiting for it to reach the proper working temperature; it is preferable that, after approximately one minute from start-up, you gradually increase the engine load.
- ❑ Do not leave the engine running at minimum speed for a long time as this does not guarantee a smooth engine operation.
- ❑ The engine speed must be increased and decreased gradually, to allow a proper operation of all engine components.
- ❑ The running speed and power values must comply with the specifications of the technical and commercial documentation.
- ❑ During use, check that:
 1. The engine coolant temperature does not reach the alarm threshold.
 2. The oil pressure remains within normal values.

SPECIAL WARNINGS

Coolant circuit

When a state of "Coolant temperature high" is found, this triggers off the limitation of the maximum power of the engine. In these cases check the efficiency of the circuit components, remembering that when the engine is warm, a pressure liable to cause hot liquid to be expelled with extreme violence is created within the cooling circuits. This results in a danger of burning.

If the temperature is considered too high, reduce speed and stop to check the state of the cooling system circuits; also check and have checked:

- a) the tension of the auxiliary member drive belt;
- b) operation of the thermostatic valve;
- c) whether or not the heat exchanger is clean.

CAUTION!



Only open the coolant tank cap if strictly necessary, and only when the engine is cold.

Lubrication circuit

When a state of “Oil pressure low”, is found, this triggers off the stoppage of the engine; in this case, check the oil level and top up if necessary, following the instructions given in the chapter on INSPECTIONS AND MAINTENANCE.

If the condition persists, contact a Service Centre.

Fuel circuit

WARNING!

Do not operated engine with fuel pressure below 20 bar (2 MPa) accurate fuel metering is not ensured and the catalytic converter might be damaged. Under this circumstances, keep engine running idle.

CAUTION!



When refueling, strictly comply with prescriptions and safety directions contained in this document.

CAUTION!



Do not loose the fittings in the fuel high pressure and low pressure circuit.

Air intake and exhaust gas circuit

Inspect the cleanliness of the air intake circuit on a regular basis. The maintenance intervals indicated in this manual vary according to the conditions in which the engine is used.

In particularly dusty environments it is necessary to carry out maintenance at more frequent intervals; with respect to the indications provided in the chapter INSPECTIONS AND MAINTENANCE.

CAUTION!



Visually check that the exhaust circuit is not blocked or damaged, so as to prevent dangerous fumes.

Electrical system of the engine

Periodically check, particularly during the winter, to ensure that the batteries are clean and in full working order, checking and topping up as indicated in the chapter INSPECTIONS AND MAINTENANCE.

In case of difficult engine start up, check terminals for tightness and have the batteries and recharging system checked for efficiency.

If batteries are replaced, observe prescribed cold discharge current intensity and capacity.

WARNING!

Contact a specialised workshop and check battery and recharging system efficiency if the voltmeter indicates a voltage below 11 V (for 12 V rated systems), or 22 V (for 24 V rated systems).

CAUTION!

The batteries contain an acid solution that will burn the skin and corrode clothing; when checking them, always wear protective clothing, gloves and goggles, do not smoke or use live flames in the vicinity, and make sure that the room they are housed in is adequately ventilated.

Emergency starting

If the battery is low, it is possible to start the engine using an auxiliary battery equivalent to the on-board battery as to electrical specifications. Observe the following instructions:

- Disconnect all the electrical devices that are currently not essential.
- Connect through an appropriate cable the positive pole of the auxiliary battery to the positive pole of the on-board battery.
- Connect through another appropriate cable the negative pole of the auxiliary battery to the negative pole of the on-board battery, preferably to an electrical ground of the vehicle located near the starter motor.
- Start the engine and remove the auxiliary cables within minutes, following the previous connection procedure in reverse order.

- If the engine does not start after various attempts, it is recommended contacting the Service Centre for adequate servicing.

Push start is discouraged; however it is possible in cases where the battery can provide the Electronic Units, the engine electric actuators and the vehicle sufficient power to adjust their operation.

WARNING!

Connect auxiliary batteries without removing the connections to the battery installed on the vehicle/means.

CAUTION!

Do not use "quick battery chargers" to start the engine as this would damage the engine electronic control units.

Directions for maintenance

The use of gaseous fuel requires strict compliance to the directions described below:

Before working on the vehicle or engine, the compartment and the areas where fuel can be present must be ventilated.

For major repairs of the vehicle or engine (e.g. welding), the supply system must be drained. It is always advisable to drain the entire system, also including the tanks, instead of draining the lines only.

If the needs for repair is not urgent (as the case may be for leakage), use up all fuel by running the engine.

Do not release the content of the tanks or fuel feeding lines into the atmosphere.

Draining procedures are dealt with in the APPENDIX.

CAUTION!



Do not use "quick battery chargers" to start the engine as this would damage the engine electronic control units.

In order to avoid damaging or demeaning the functioning of the Electronic units equipping the engine or the vehicle, observe the following prescriptions:

- Do not remove the vehicle battery connections when the engine is running or when the starter switch is on RUN.
- Do not disconnect the connectors of the Electronic units with the engine running or with the key switch in position RUN. If necessary, perform the operation within minutes after having set the key switch in the stop position and shut down the engine.
- Disconnect the battery from the on-board system in the event that a recharge is necessary.
- After every maintenance operation involving disconnection of the battery/ies, make sure that the terminals have been properly tightened onto the poles again.
- Carrying out arc welding operations by building or repairing the vehicle, disconnect the positive terminal from the battery and connect it to the electrical ground, remove the connections from the Electronic units observing the information supplied. If the welding operations involve parts in the proximity of Electronic units, disassembly them from the vehicle.
- Carry out direct current weldings being careful to connect the ground terminal in the proximity of the concerning point.
- Do not paint appliances, components and electrical connectors equipping the engine.
- Remove from the vehicle any Electronic units if it has to be exposed to temperatures above 80 °C.

- ❑ It is desirable disconnect the negative pole of the battery before carrying out operations involving the electrical system of the vehicle.

CAUTION!



Never spray with detergents or wash the engine when equipped with the electronic systems or electrical components. For requests for information contact a Service Centre.

Safeguarding the anti-pollution devices

The proper operation of the anti-pollution devices ensures the protection of the environment and the best engine performance as well. Keeping them in good state is then essential for an economic and environment-friendly driving.

Catalytic converter and oxygen sensor

Engine electronic control system uses the information from oxygen sensor (Lambda sensor) for injection control optimization. Thanks to this sensor, the amount of pollutants generated by the engine drops dramatically and the abatement process in the catalytic converter is improved. The use of non-compliant fuels or a poor maintenance of the system can reduce the efficiency of its components and set off some strategies that limit engine performance with the purpose to contain pollution.

Strict compliance to the programmed maintenance schedule and care to avoid damage to system components ensure long life and higher efficiency to the engine.

RUNNING-IN

Thanks to the engine construction advanced technology, non special running-in procedure is required. However it is recommended to avoid at least for the first 50 hours, using the engine at high speeds for extended periods of time.

REFILLING

Parts to be refilled		N60ENTG litres (kg)
Cooling circuit ⁽¹⁾		10
Lubrication circuit ⁽²⁾		
Total capacity ⁽³⁾		13.1 (11.8)
Periodical replacement:		
Oil sump at minimum level		8 (7.2)
Oil sump at maximum level		10.8 (9.7)
Power steering oil ⁽⁴⁾		(6)
Fuel tank ⁽⁵⁾		(6)

* Quantities for engine only in standard configuration.

(1) Mixture of water and PARAFU 11 at 50% also in the hot season. As an alternative to PARAFU 11, use equivalent product with the characteristics specified in the SAE J 1034 international standards.

(2) Oils with characteristics as reported below:

Lubricants for NGC engines to ACEA E6 (TBN>12) - IVECO Std. 18-1809 (N62 class).

The viscosity to ambient temperature relationship is shown in the table in Appendix.

Max acceptable oil consumption is 0.5 % of fuel consumption.

(3) Quantities for first filling of engine, oil sump and filter.

(4) Oil type ATF Dexron II D, up to IVECO Std. 18-1807

(5) Fuel (NGC) up to Std.G20-G23-G25 - CE 2001/27 and ISO/TC 58/SC3 no. 755. Natural gas content (CH₄) > 83%. Do not deliberately add glycol.

A minimum content of oil (70 p.p.m.) is required for proper operation of the fuel supply system components. This amount is typically contained in the gas as a consequence of small leakage of oil from the pumping compressor during transfer.

(6) Refer to the directions supplied by the manufacturer of the means.

WARNING!

The use of fuels non compliant to the requirements contained in this document might prevent the obtainment of the power and torque rating reported for the different engines.

Make sure that the fuel is free of impurities or substances that might damage the tank or catalytic convert and compromise safety in operation.

■ INSPECTIONS AND MAINTENANCE

MAINTENANCE PERSONNEL

Engine control and maintenance operations reported below require a good knowledge and training and the observance of the standards and directions for personal safety and safeguard of equipment.. These operations must be carried out by experienced and qualified personnel as indicated below.

❑ **Inspections:** workshop operators or vehicle's user if authorized.

❑ **Periodic maintenance:** authorized qualified personnel with suitable tools and protection devices.



❑ **Extraordinary maintenance:** authorized qualified personnel with technical know-how and specific tools.



The most qualified Assistance Centres are those which make up the FPT Technical Assistance Network.

ACCIDENT PREVENTION

- ❑ Always wear safety shoes and overalls.
- ❑ Do not wear loose garments, rings, bracelets and/or necklaces near the engines or moving parts.
- ❑ Wear safety gloves and goggles when:
 - refilling batteries with acid solution
 - refilling with inhibitors or deicers
 - replacement or refilling of lubricants (hot engine oil can cause burns. Only carry out these operations when the oil has dropped to a temperature of below 50 °C).
- ❑ When working in the engine compartment, pay particular attention to how you move, to avoid contact with moving parts or components at high temperature.
- ❑ Wear goggles when using high pressure air jets (maximum air pressure used to clean is 200 kPa (2 bar, 30 psi, 2 kg/cm²).
- ❑ Wear a protective helmet when working in an area where there are suspended loads or systems installed at head-height.
- ❑ Use protective hand creams.
- ❑ Replace wet overalls immediately.
- ❑ Always keep the engine clean, removing oil, grease and coolant stains.
- ❑ Store cloths in flame-proof containers.
- ❑ Do not leave foreign bodies on the engine.
- ❑ Use suitable, safe containers for used oil.

CAUTION!



Before starting maintenance works, the compartment and the area where fuel can be present must be ventilated.

FREQUENCY

The maintenance intervals indicated below take into account the typical working factors for various types of engine use; the most suitable interval for maintenance operations for the various applications will be indicated by the maintenance staff, according to the way and working conditions in which the engine is used.

Checks	Frequency
Inspection of technical fluid level (oil, coolant, hydraulic power steering oil)	Before use
Check fluid level in tanks	Before use
Check/restore the level of electrolytic solution in the batteries and clean terminals	Every six months
Check air filter conditions	Every six months

 Programmed maintenance	Frequency
Change engine lubricant	20,000 km/1,300 h ⁽¹⁾⁽²⁾
Replace engine lubricant filter	20,000 km/1,300 h ⁽³⁾
Check accessory belt conditions	20,000 km/1,300 h
Check and lubricate throttle valve actuators	20,000 km/1,300 h
Replace fuel filter	60,000 km/3,900 h ⁽⁴⁾
Check pressure regulator compensation and heating circuits	60,000 km/3,900 h *
Replace spark plugs	60,000 km/3,900 h
Replace ignition coil extensions	60,000 km/3,900 h
Replace oil vapor filter (if available)	60,000 km/3,900 h ⁽²⁾
Engine electronic control system test	60,000 km/3,900 h
Check tightness of high and low pressure fuel lines	60,000 km/3,900 h *
Check electrical wire integrity	60,000 km/3,900 h *
Check fan electromagnetic coupling	60,000 km/3,900 h
Replace accessory belt	80,000 km/5,200 h ⁽⁵⁾
Replace A/C compressor belt	120,000 km/7,800 h ⁽⁵⁾



Programmed maintenance

Frequency

Replace accessory belt tightener	240,000 km/15,600 h ⁽⁵⁾
Check coolant density	Yearly
Change coolant	2 years
Change air filter and clean casing	2 years ⁽⁵⁾
Change hydraulic oil (services)	3 years

* First check before 2,000 km or 40 hours.



Extraordinary maintenance

Frequency

Replace shutoff valve rotating element	180,000 km
Replacement of timing control gears	400,000 Km/26,000 h
Valve clearance regulation:	60,000 Km/3,900 h
Replacement of injectors/intake manifold rubber unions	5 years

- 1) To be performed every year even if the operating hours expected are not met.
- 2) Frequency applicable to lubricants as provided in REFILLING table.
- 3) Use only filters with the following features:
 - filtering degree < 12 µm
 - filtering efficiency β > 200.
- 4) These intervals are applicable to the use of fuels compliant to the requirements contained in the REFUELING table and free of impurities.
- 5) Frequency is based on ambient and efficiency/wear conditions of the product.

WARNING!



The extraordinary maintenance operations described hereunder fall within the exclusive competence of manufacturer's personnel or specialised personnel having proper working tools and adequate protection devices. The procedure and modality for carrying out these operations are illustrated in the FPT Technical and Repair Manual.

Periodical inspection of tanks

Fuel tanks must be regularly inspected at maximum intervals of 36 months as indicated in the ECE- ONU R110 regulations.

The manufacturer of the vehicle on which the tanks are installed can require more severe and rigorous periods and procedures. Also, the tanks must be submitted to extraordinary inspection under the circumstances indicated in Section 7 of the ISO/DIS 19078 standards, i.e.: accident, fire or overheating, chemical damage, excessive pressure or improper use, including the damages occurred during transportation

The inspection must be carried out by a qualified inspector as defined in Section 5 of the ISO/DIS 19078 standard by means of the specific equipment indicated in Section 7 of the standard above.

Apply regulations and standards in force in the country where the vehicle is going to be used.

CAUTION!



Before starting any works on them, make sure that tanks are completely empty.

CAUTION!



Do not use tanks subject to crash or fire or showing evident defects.

HOW TO

The procedures below refer to onboard systems and components compliant to IVECO MOTORS – FPT specifications.

We recommend that maintenance engineers work in compliance with the DIRECTIONS FOR MAINTENANCE contained in this document.

Draining of engine fuel supply lines

1. Close manual shutoff valve upstream of pressure regulator.
2. Start the engine and wait until it stops to exhaust all gas still contained in lines and reducer.
3. Rotate ignition key switch to OFF and wait a few minutes before cutting power off from main switch or by disconnecting battery terminals.

If the engine cannot be started, follow the procedure below:

1. Close manual shutoff valve upstream of pressure regulator.
2. Loosen the hose union between pressure regulator and fuel sender on engine to release the gas contained in the regulator and fuel sender (about 1 dm³). Do not use open flames in the area nearby.
3. With ignition key switch set to OFF cut power off from main switch or by disconnecting battery terminals.

On completion of maintenance or repair works:

1. Reconnect hose to regulator, and interpose a new aluminum gasket spread with some grease on both sides.
Use a torque wrench (22 MA) to tighten to 70 Nm.
2. Open the valve downstream of the reducer and restore electrical supply.

3. Turn ignition key switch to RUN and inspect unions for leakage using a soapy solution.

CAUTION!



For operations involving components in the vicinity of tanks or installed on them, the supply system including the tanks must be drained. If the needs for repair is not urgent (as the case may be for leakage), use up all fuel by running the engine.

CAUTION!



Before starting any maintenance works, make sure that circuits, and tanks if necessary, are completely empty. Any defective components might cause gas leakage or prevent complete bleeding of the tanks.

WARNING!

If any components, pipes and/or high or low pressure circuit pipes and/or unions are replaced, hydraulic tightness test must be run before filling the system with gas. The testing procedures are dealt with in the APPENDIX.

WARNING!

It is advisable that operators must observe the prescriptions described in the section SPECIAL WARNINGS.

Engine lubricant level inspection

To avoid risk of burns, only proceed when the engine is not running and is cool.
(see the illustrations in the section ENGINE TECHNICAL DATA).

- ❑ Make sure that the vehicle is levelled.
- ❑ Using the dip-stick (1), that the oil quantity is between MIN and MAX limits.
- ❑ If the level is insufficient, remove the cap located on the top of the cylinder head and refill the lubricant through the filler.

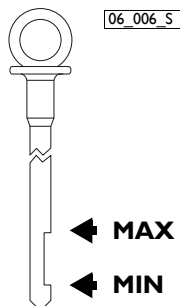

WARNINGS!

- ❑ After refilling make sure oil level does not exceed the limit "Max" on the stick.
- ❑ Insert the dip-stick all the way down and tighten the cap by turning it clockwise until it comes to a full stop.

Coolant level inspection

Proceed only with engine not running and at low temperature to avoid any risk of burns.

- ❑ With the engine at low temperature, make sure that the fluid level in the expansion tank is above the minimum level.
- ❑ Visually check that the fluid level is not more than 2/3 of the height of the tank in order to enable any increase in volume of the fluid caused by the temperature increase.
- ❑ Top up the tank from the filler cap (1) if necessary, using clean water. Do not use distilled water; see the table REFILLING.

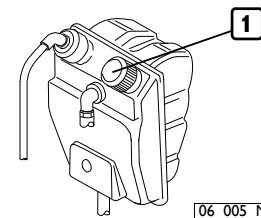

Note: if the refill operations occur frequently a diagnosis of the cooling circuit is necessary.

In the event that only the heat exchanger without the expansion tank is available on the vehicle, refill it if necessary, paying attention that the fluid does not saturate the internal volume of the exchanger in order to enable any increase in volume of the fluid caused by the temperature increase.

CAUTION!



When the engine is warm, a pressure liable to cause hot liquid to be expelled with extreme violence is created within the cooling circuits. This results in a danger of burning.

Checking power steering oil (Only engine with standard configuration)

- ❑ Extract the sensor from the storage tank only when the engine is not running.
- ❑ Check that the level is between the limits. Top up if necessary according to the table REFILLING.
- ❑ Start the engine and perform any steering operations.
- ❑ Close the plug again tightening it properly after verifying that the level is still between the limits.

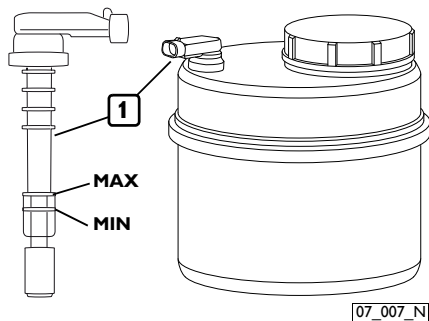

Checking/topping up electrolyte level in batteries

Place the batteries on a level surface, then proceed as follows.

- ❑ Visually check that the fluid level is between the "Min" and "Max" limits; in the absence of references, check that the fluid covers the Lead plates inside the elements for about 5 mm.
- ❑ Top up with distilled water only those elements in which the level is below the minimum.
- ❑ On this occasion, make sure that the terminals and clamps are clean, properly tightened and protected by Vaseline.

WARNING!



If all the elements of the battery need refilling with a considerable quantity of distilled water, contact specialised technical personnel in order to perform a diagnostic check on the efficiency state of the recharge system and battery.

CAUTION!



- ❑ The batteries contain sulphuric acid, which is extremely caustic and corrosive; always wear protective gloves and goggles when topping them up. Whenever possible it is recommended that this control be carried out by specialised personnel.
- ❑ Do not smoke or use live flames near the batteries during the control, and make sure that the room you are working in is adequately ventilated.

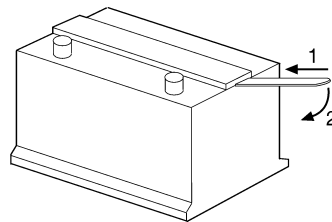

Some types of battery have a single cover for all the inspection plugs. To access the elements, use a lever as shown in the figure.

Replacing the lubricant oil

Only proceed with the engine stopped and at a low temperature, so as to avoid the risk of burning.

- ❑ Place a container under the drainage plug to collect the used oil (see illustrations in the chapter ENGINE TECHNICAL DATA).
- ❑ Unscrew the filler cap and remove the drain plug. Wait until the sump has been fully drained, then put the plug back in place.
- ❑ Fill up through the feeder hole on the timing system cover or as shown in the figure, using the types and amounts of oil indicated in the table REFILLING.
- ❑ Using the dip-stick, check that the oil level is between the "Min" and "Max" levels.
- ❑ Dispose of used oil according to current regulations.

WARNINGS!

- ❑ *After refilling make sure that the oil level is not above the MAX limit on the dip-stick.*
- ❑ *Make sure that the dip-stick has been fully inserted and the filler cap tightened clockwise up to a complete stop.*

Replacing the engine oil filter

Only proceed with the engine stopped and at a low temperature, so as to avoid the risk of burning.

Only use filters with a filtration level equivalent to the ones you are replacing (see section FREQUENCY).

- ❑ Place a container under the filter support, to collect the used oil.
- ❑ Unscrew the filter and remove it (1).
- ❑ Carefully clean the surfaces of the support that are in contact with the seal (2).
- ❑ Moisten the new filter seal with a thin layer of oil.
- ❑ Hand screw the new filter into place until the seal gasket touches the support, then lock by a further 3/4 of a turn.
- ❑ Dispose of the old filter according to current regulations.

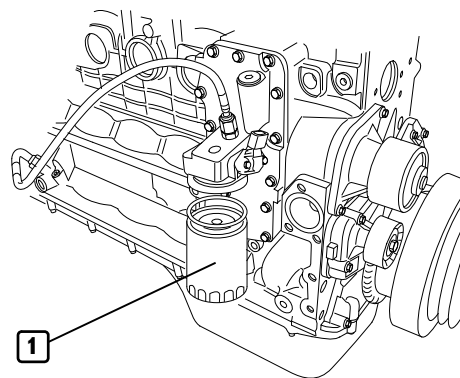

06_010_N

Checking tension and state of the auxiliary member drive belt

Operate after ensuring that any electrical supply is shut off to prevent any accidental engine start and with low engine temperature to avoid the risk of burns.

- ❑ Remove any casing protecting the pulleys.
- ❑ Check that the belt is not torn or worn, and that there are no lubricants or fuel on it. If this is not the case, replace them.
- ❑ At the same time, make sure that the tensioning device is working properly, proceeding as shown in the figure.
- ❑ Replace the guard casing in its housing, and lock all the retaining elements.

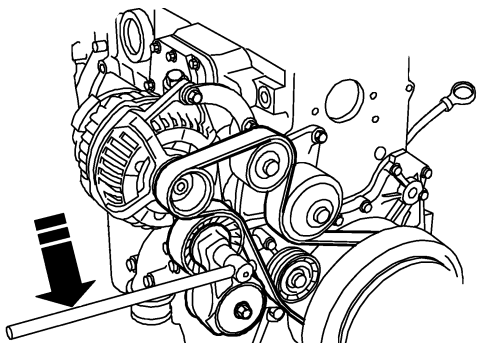

74178

Fuel filter replacement

Turn ignition key switch to OFF and check that fuel supply lines are empty.

The procedure for line draining are describe in "draining of engine fuel supply lines".

1. Be careful of residual fuel bleeding when removing the cap (1).
2. Replace filter.
3. Refit cap and tighten to the torque of 11 Nm.
4. Restore the conditions for correct engine operation.

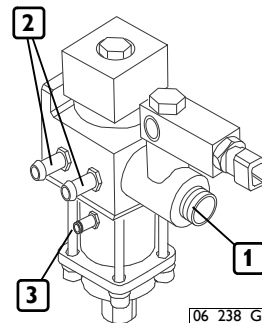

06_238_G

Check pressure regulator heating circuits

Operate with engine off and at low temperature to avoid the risk of burns.

Inspect engine coolant supply and return lines connected to the unions (2) for any abrasions, tears or chokes and that fasteners are securely tightened.

Start the engine and wait some time before checking that the temperature of regulator body is higher than the ambient temperature.

Replace lines if necessary. Also inspect pressure compensation hose (3) for integrity.

Engine electronic control system test

The diagnostic inspection can be carried out by using the diagnostic tool supplied by the FPT Technical Service Network to the appropriate connector.

The inspection could underline that the system is operating even if some problems are present. In this case make provision to carry out an exhaustive check-up.

Check tightness of high and low pressure fuel lines

Check that manual shutoff valves on tanks and in the system are open. Turn ignition key switch to RUN to supply electric shutdown valves: check that valves open regularly and inspect all system hoses.

Use a soapy solution to detect any fuel leakage.

In case of fuel leakage from the system, bleed the system or part of it as necessary, and replace any defective components.

Draining procedures are dealt with in the APPENDIX.

CAUTION!



If valves must be removed from tanks make sure that these are empty.

After removal, valves are not reusable and must be thrown away.

Check electrical wire integrity

Operate after ensuring that any electrical supply is shut off and with low engine temperature to avoid the risk of burns.

Visually inspect wires for any abrasions or tears and for proper fastening to mounting brackets. Inspect wire routing to avoid any contact with hot components. Check electrical and electronic connector fasteners for efficiency.

If any repairs are required, these must be carried out by experienced personnel.

Fan electromagnetic coupling inspection

Proceed only when the engine is not running and the key switch is set on REST.

1. Disconnect the coupling electric connection
2. Make sure the fan is rotating freely.
3. Apply a 24 V voltage to the coupling, through a suitable harness provided with connector.
4. Apply a sufficient rotation torque to the fan, in order to test resistance.
5. Replace the coupling in case the fan rotates without excessive resistance.
6. At the end of the intervention, restore the control electric circuit continuity.

Cleaning the air filter

(Refers to FPT components)

Only proceed with the engine stopped.

- ❑ Remove the filter cover (1) after first unscrewing the locking handle.
- ❑ Remove the external cartridge (2), after unfastening the second locking handle; during this operation, take care to ensure that no dust get into the sleeve.
- ❑ Check that there is no dirt. If there is, clean the filter element as indicated below.
- ❑ Blow dry compressed air through the filter element, from the inside outward (maximum pressure 200 kPa). Do not use detergents; do not use diesel.
- ❑ Never use tools to beat the filter element, and check its condition before replacing it.
- ❑ Replace the filter if any breakages or tears are found.
- ❑ Check that the gasket at its base is in good condition. Some filter systems are fitted with a second filter element (3) which does not require cleaning; this must be replaced at least once every 3 changes in the main element.
- ❑ Reassemble by repeating the above operations in reverse order.
- ❑ Set up the mechanical blockage indicator for operation by pressing the button located on the top part of the indicator. This operation is not necessary if there is an electrical sensor.

WARNING

Take care to ensure that the parts are reassembled correctly. Imperfect assembly might result in unfiltered air being sucked into the engine, causing serious damage.

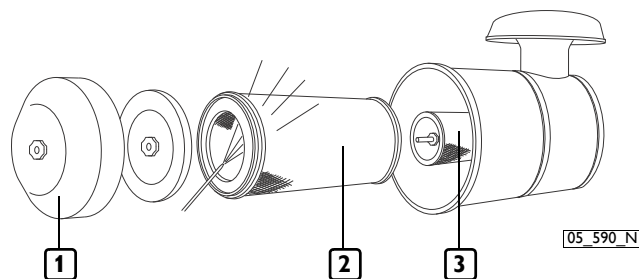

Replacing the oil vapour filter

Only proceed with the engine stopped and at a low temperature, so as to avoid the risk of burning.

- Loosen the screws and remove the cover (1) of the filter housing.
- Remove the two filters and proceed to the replacement.
- Install the cover again.

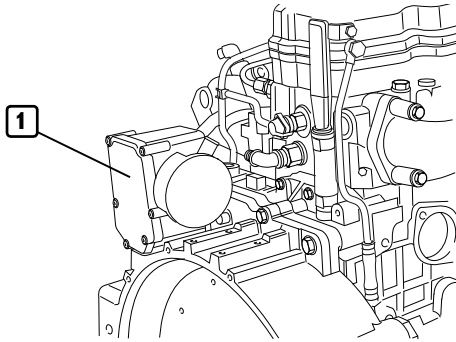

06_012_N

Checking coolant density or replacing coolant

Only proceed with the engine stopped and at a low temperature, so as to avoid the risk of burning.

In the event that a mixture of PARAFLO 11 and water is used, the density value is equal to $1,0675 \text{ g/cm}^3$ (at a temperature of $15 \text{ }^\circ\text{C}$).

For replacing the coolant, observe the following procedure:

1. Provide suitable containers to ensure that no coolant is dispersed into the environment.
2. Remove the cap of the expansion tank.
3. Loosen the seal elements, remove the sleeves connecting the engine circuit to the heat exchanger and wait until it has emptied completely. When empty, repair the circuit making sure that the sleeves are perfectly sealed.
4. Fill up the circuit as indicated in the table REFILLING.
5. Bleed the circuit and top-up if necessary.

Replacing power steering oil

Only proceed with the engine stopped.

- Open the cap of the storage tank and proceed depending on the necessity related to the vehicle building.

MOVING THE ENGINE

The operations necessary to disconnect and subsequently reconnect the engine must only be carried out by technicians from Service Centres.

When lifting the engine only, use the eyebolts indicated in this manual in the section ENGINE TECHNICAL DATA and marked on the engine with special stickers.

Lifting must be carried out using a rocker arm that keeps the metal cables supporting the engine parallel, using all the eyebolts provided simultaneously; the use of a single eyebolt only is not allowed.

The engine lifting system must have a capacity and size suited to the weight and dimensions of the engine; check that there is no interference between the lifting system and the engine components.

Do not lift the engine before removing the transmission members that are coupled to it.

DISPOSAL OF WASTE

The engine is made up of parts and elements that, if discarded, may cause damage to the environment.

The materials listed below must be handed over to specialised Collection Centres; the laws in force in the various Countries foresee severe penalties for transgressors:

- Starter batteries.
- Used lubricants.
- Mixtures of water and antifreeze.
- Filters.
- Additional cleaning materials (e.g. greasy or fuel-soaked cloths).

■ LONG ENGINE INACTIVITY

PREPARING THE ENGINE FOR A LONG PERIOD OF INACTIVITY

In order to prevent oxidation of the internal parts of the engine and of certain components in the injection system, when the engine is expected to be inoperative for periods of more than two months, the following operations must be carried out in preparation for this:

1. Drain the lubricant from the sump, after first warming up the engine.
2. Fill the engine with protective oil type 30/M (or alternatively oil that complies with MIL 2160B type 2 specifications), up to the "minimum" level indicated on the dip-stick. Start the engine and keep it running for approximately 5 minutes.
3. Nebulise approximately 10 g per litre displacement of 30/M protective oil into the turbocharger suction inlet, during the pressurised filling operation described in the previous point.
4. Close all the suction, delivery, ventilation and bleeder openings in the engine with suitable plugs, or seal them with adhesive tape.
5. Drain the residual 30/M protective oil from the sump. This oil can be used again for a further 2 preparation operations.
6. Fit signs reading ENGINE WITHOUT OIL to the engine and to the on-board control panel.
7. Drain the coolant, if it has not been mixed with suitable antifreeze and corrosion inhibitors, and affix a sign to indicate the fact.

In the event of prolonged inactivity, the operations described must be repeated every 6 months, following the procedure given below:

- A) drain the 30/M protective oil from the sump;
- B) repeat the operations described from point 2 to point 5.

Should you intend to protect external parts of the engine, proceed by spraying OVER 19 AR protective liquid on unpainted metal parts, such as the flywheel, pulleys and the like, avoiding belts, connector cables and electrical equipment.

RESTARTING THE ENGINE AFTER A LONG PERIOD OF INACTIVITY

1. Drain the residual 30/M protective oil from the sump.
2. Fill the engine, as prescribed, with lubricant of the type and amount indicated in the table REFILLING.
3. Drain the CFB protective fluid from the fuel circuit, carrying out this operation as indicated under point 3. of PREPARING THE ENGINE FOR A LONG PERIOD OF INACTIVITY.
4. Remove the plugs and/or seals from the suction, delivery, ventilation and bleeder openings in the engine, restoring it to a normal state of use. Connect the turbocharger suction inlet to the air filter.
5. Reconnect hose to pressure regulator, and interpose a new aluminum gasket spread with some grease on both sides. Use a torque wrench (22 MA) to tighten to 70 Nm.
6. Check the engine and fill it up with coolant as prescribed, bleeding it if necessary.
7. Start the engine and keep it running until the idling speed rate has stabilised completely.
8. Check that the instruments on the on-board control panel/s are showing plausible values, and that no alarms are shown.
9. Stop the engine.
10. Remove the ENGINE WITHOUT OIL signs from the engine and from the on-board control panel.

■ ENGINE MALFUNCTIONS

The electronic unit overseeing management and control of all operation of the engine is capable of recognising any malfunctions that may occur, and of adopting strategies that will allow you to proceed in full safety.

The event, signalled by light-up of the EDC MALFUNCTION indicator on the on-board control panels, results in programmed limitation of power within certain thresholds, set according to the severity of the case.

In the case of temporary malfunctions the reduction in performance will remain in force until the engine is stopped.

Failure indication modes

Different failures are signaled by different modes of illumination of the indicators.

Off

Regular operation or failure condition, covered by safety strategies.

On

An anomaly has been detected and a power limitation has occurred but it is possible to continue driving slowly. Contact the Technical Service Network and ask for instructions.

Blinking

A serious anomaly has been detected and the engine must be stopped. It is possible an emergency stop generated by the electronic unit. Reach a safety condition, stop the engine, and call out the Technical Service Network.

Accelerator electronic circuit malfunction

Special attention has been paid to safety systems to prevent accidental acceleration and ensure that vehicle can still operate in the occurrence of a failure.

The signals from the sensors on accelerator pedal and throttle valve actuator are constantly monitored by the electronic control system. If any inconsistency is detected in the signals, the throttle is controlled strategically in order to ensure a engine speed that allows the vehicle to be operated.. Any failures that might impair throttle control in safe conditions causes engine stop.

WARNINGS!

The use of fuels that are non compliant to the specifications or contain impurities can reduce engine power. If this condition should occur, check the conditions of the fuel filter inside the pressure regulator.

CAUTION!



Do not leave vehicles or machines with the engine running without first putting the parking lock or brake on

■ BEHAVIOUR IN AN EMERGENCY

The user of a vehicle that has been constructed according to safety regulations, when following the instructions provided in this manual and the indications given on the engine labels, will be working in safe conditions.

Should improper conduct result in accidents, always request the intervention of trained first aid specialists immediately.

In an emergency and while awaiting the arrival of first aid specialists, follow the instructions given below.

Engine malfunctions

When operating with a malfunctioning engine, take the greatest possible care when manoeuvring and make sure that all those aboard are holding firmly to safe hand-holds (see section on ENGINE MALFUNCTIONS).

Gas leakage



1. Stop engine.
2. Close tank shutoff valves on the vehicle and, if you are in a petrol station, also shut off the valves on fuel distributor and tanks whose location must be indicated with labels.
3. Disconnect electrical system main switch.

4. Prevent the access to hazard area and ask unauthorized people to leave the area.
5. Immediately inform competent authorities and seek technical assistance.
6. Ventilate the area.

Fire



1. Do not put out flames produced by the combustion of gas leakage. If possible, cool the parts that might get in contact with flames.
2. Close tank shutoff valves on the vehicle and, if you are in a petrol station, also shut off the valves on fuel distributor and tanks whose location must be indicated with labels.
3. Disconnect electrical system main switch.
4. Help any injured people. Helping injured people has priority on extinguishing the fire.
5. If it has propagated to the surrounding area, put out fire using the extinguishing means available. Move any vehicles in the vicinity away from the dangerous area.
6. Immediately call the FIRE BRIGADES

Burns and scalds

1. Extinguish any flames on the burned person's clothing, by:
 - throwing water over them;
 - using a powder fire-extinguisher, without directing the jet at the person's face;
 - covering with blankets or rolling the victim on the ground.
2. Do not attempt to remove pieces of clothing that may have stuck to the skin;
3. In the case of scalding, immediately but carefully remove any clothing that may be soaked in the hot liquid;
4. Cover the burn with a special burn dressing or sterile bandage.

Carbon monoxide intoxication (CO)

Carbon monoxide from the engine exhaust is without smell, and is dangerous both because it causes intoxication, and because when combined with air it forms an explosive mixture.

In closed rooms, carbon monoxide is extremely dangerous, as it can reach critical concentrations within a very short time.

When assisting an intoxicated person in a closed room:

1. Ventilate the room immediately, to reduce the concentration of gas.
2. When entering the room, hold your breath, do not light flames, lights or ring electric doorbells or phones, to avoid the risk of explosion.
3. Carry the intoxicated person out into the fresh air or into a well ventilated room, resting him on one side if he is unconscious.

Electrocution

The engine's electrical 12 V or 24 V electrical system does not involve the risk of electrocution, however, in the event of a short-circuit caused, for example, by a metal tool, there is a risk of burning due to overheating of the object through which the electrical current runs. In these circumstances:

1. Remove the object that caused the short-circuit, using means that provide sufficient heat insulation.
2. Switch off the power at the main switch, if there is one.

Injuries and fractures

The vast number of possible circumstances and the specific nature of operations required means that the intervention of a medical team is necessary.

1. In the event of bleeding, keep the edges of the wound pressed together until help arrives.
2. If there is any suspicion of a fracture, do not move the injured part and only move the patient if absolutely necessary.

Caustic burns

Caustic skin burns are caused by contact with extremely acid or alkaline substances.

For electric maintenance technicians these are typically caused by acid from batteries; in these circumstances, proceed as follows:

1. Remove any clothing soaked in the caustic substance.
2. Wash the area with lots of running water, avoiding parts that have not been burned.

If either battery acid, lubricants or diesel come into contact with the eyes: wash the eyes with water for at least 20 minutes, keeping the eyelids open so that the water flows over the eyeball (move the eye in all directions to wash more thoroughly).

■ APPENDIX

PROCEDURE FOR SYSTEM EMPTING

Partial emptying

Move the vehicle in a safe area with no sources of ignition in a range of minimum 5 meters.

1. Cut supply off the electrical system by disconnecting the main switch (if fitted).
2. Disconnect the cables from battery terminals and connect them to each other.
3. Connect the vehicle to earth.
4. Check that manual shutoff valves on all tanks are closed.
5. Disconnect fuel inlet line from pressure reducer and connect it to the rubber hose (natural gas compatible) for gas discharge at a minimum distance of 5 meters from any ignition source.
6. Take special care during gas discharge. Cooling resulting from fast decompression can cause skin freezing.
7. When the gas has been exhausted, check that system pressure is zero.

WARNINGS!

Partial gas draining does not provide the safety conditions required for operation on tanks.

Complete emptying

1. Follow the procedure described above for partial gas draining.
2. Check that manual shutoff valves on all tanks are closed.
3. Undo shutoff valve top nut to remove the coils.
4. Slowly undo the seats with solenoid valve shutters. Beware of gas release from valve body.
5. Remove shutter from their seat.
6. Retighten the seats without shutters.
7. Partially open the shutoff valves to allow pressurized fuel release through the hoses.
Cooling resulting from fast decompression can cause skin freezing.
8. When the gas has been exhausted, check that system pressure is zero.
9. Try to start the engine to make sure that no residual gas is still contained in the injection system.

PROCEDURE FOR SYSTEM TIGHTNESS TEST

The system tightness test must be carried out by qualified personnel at an authorized workshop for certified test results and repair actions required to ensure tightness.

The test can be carried out only with tanks containing gas at a minimum pressure of 8 bars. If needed, add nitrogen at the required pressure.

The presence of pressurized gas expels the liquid contained in the system under test.

1. Pull out electrical connectors from shutoff valves on tanks.
2. Close all valves on tanks.
3. Disconnect fuel feeding line to pressure regulator.
4. Connect a high pressure pump to the hose removed from regulator and deliver gasoil at a pressure of 300 bars.
5. Monitor pressure for 15 minutes by means of pressure gauge to ensure that no pressure drop occurs. Any pressure drops is an evidence of leakage that must be eliminated.
6. Remove the high pressure pump and connect the hose to a container to collect the gasoil from the system.
7. Restore electrical continuity of shutoff solenoid valve connectors on tanks.
8. Supply the electrical system and slowly open the manual shutoff valves for line bleeding.
9. Restore connection to pressure regulator as specified.

Tightening torques:

Inlet line to pressure regulator: 36 Nm.

Pressure regulator coil: 13 Nm.

Outlet line from pressure regulator: 70 Nm.

Shutoff valve shutter seats : 28 Nm.

