

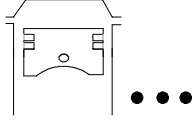
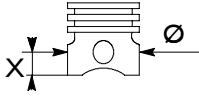
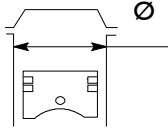
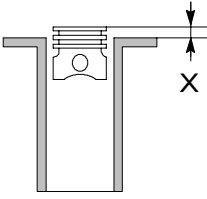
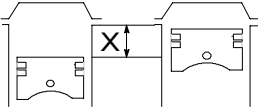
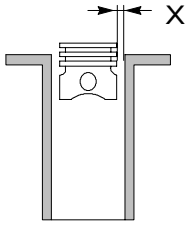
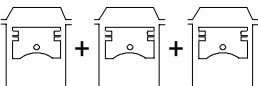
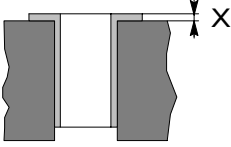
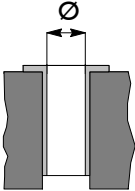
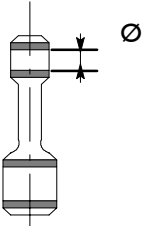
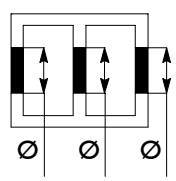
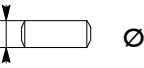
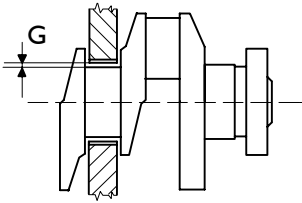
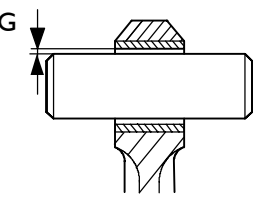
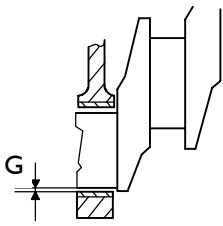
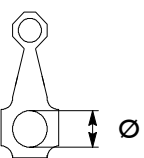
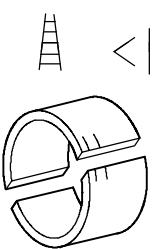
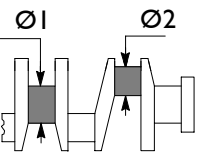
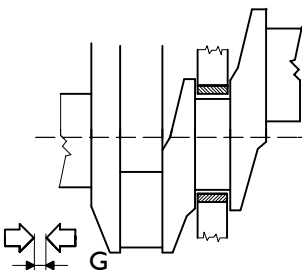
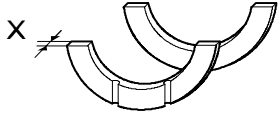
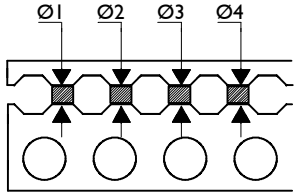
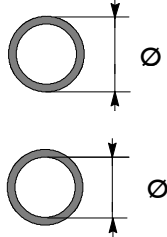
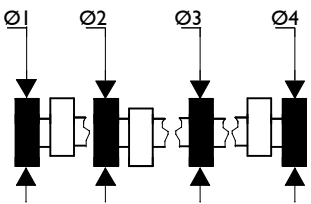
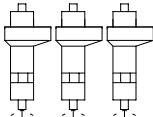
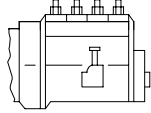

<p>1</p> 	<p>Q.ty</p>	<p>6</p>	<p>6</p> 	<p>X mm</p>	<p>33</p> <hr/> <p>136,813 ÷ 136,827 CLASS A</p> <hr/> <p>136,848 ÷ 136,862 CLASS B</p>
<p>2</p> 	<p>Ø mm</p>	<p>137</p>	<p>7</p> 	<p>X mm</p>	<p>-0,275 ÷ +0,225</p>
<p>3</p> 	<p>X mm</p>	<p>156</p>	<p>8</p> 	<p>X mm</p>	<p>0,128 ÷ 0,177</p>
<p>4</p> 	<p>cm³</p>	<p>13798</p>	<p>9</p> 	<p>X mm</p>	<p>0 ÷ +0,065</p>
<p>5</p> <p>Q</p>		<p>15 : 1</p>	<p>10</p> 	<p>Ø mm</p>	<p>136,955 ÷ 136,990 CLASS A</p> <hr/> <p>136,990 ÷ 137,025 CLASS B</p>

<p>11</p> 	<p>Ø 1 mm</p>	<p>50,019 ÷ 50,035</p>	<p>16</p> 	<p>Ø 1 mm</p>	<p>107,976 ÷ 108,001</p>
<p>12</p> 	<p>Ø 1 mm</p>	<p>49,995 ÷ 50,000</p>	<p>17</p> 	<p>G mm</p>	<p>0,083 ÷ 0,148</p>
<p>13</p> 	<p>G mm</p>	<p>0,019 ÷ 0,040</p>	<p>18</p> 	<p>G mm</p>	<p>0,051 ÷ 0,139</p>
<p>14</p> 	<p>Ø mm</p>	<p>88,482 ÷ 88,504</p>	<p>19</p> 	<p>mm</p>	<p>– 0,254 – 0,508 – 0,762 – 1,016</p>
<p>15</p> 	<p>Ø 1 mm</p>	<p>102,874 ÷ 102,901</p>	<p>20</p> 	<p>G mm</p>	<p>0,056 ÷ 0,328</p>
<p></p>	<p>Ø 2 mm</p>	<p>84,708 ÷ 84,735</p>	<p></p>	<p></p>	<p></p>

<p>21</p> 	<p>X mm</p>	<p>2,311 ÷ 2,362</p>	
<p>22</p> 	<p>mm</p>	<p>Ø1</p>	<p>68,515 ÷ 68,550</p>
	<p>mm</p>	<p>Ø2</p>	<p>68,015 ÷ 68,050</p>
	<p>mm</p>	<p>Ø3</p>	<p>67,515 ÷ 67,550</p>
	<p>mm</p>	<p>Ø4</p>	<p>67,015 ÷ 67,050</p>
<p>23</p> 	<p>mm</p>	<p>Ø1</p>	<p>68,618 ÷ 68,669</p>
	<p>mm</p>	<p>Ø2</p>	<p>68,135 ÷ 68,186</p>
	<p>mm</p>	<p>Ø3</p>	<p>67,627 ÷ 67,678</p>
	<p>mm</p>	<p>Ø4</p>	<p>67,119 ÷ 67,170</p>
	<p>mm</p>	<p>Ø1</p>	<p>62,599 ÷ 62,660</p>
	<p>mm</p>	<p>Ø2</p>	<p>62,099 ÷ 62,160</p>
	<p>mm</p>	<p>Ø3</p>	<p>61,600 ÷ 61,660</p>
	<p>mm</p>	<p>Ø4</p>	<p>61,100 ÷ 61,160</p>
<p>24</p> 	<p>mm</p>	<p>Ø1</p>	<p>62,500 ÷ 62,530</p>
	<p>mm</p>	<p>Ø2</p>	<p>62,000 ÷ 62,030</p>
	<p>mm</p>	<p>Ø3</p>	<p>61,500 ÷ 61,530</p>
	<p>mm</p>	<p>Ø4</p>	<p>61,000 ÷ 61,030</p>
<p>25</p> 	<p>ORDER</p>	<p>1 - 5 - 3 - 6 - 2 - 4</p>	
<p>26</p> 	<p>I.P.</p>	<p>PE 6P 120A</p>	
	<p>REG.</p>	<p>MECHANICAL "RQV"</p>	
<p>27</p> <p>OIL PRESSURE</p> 	<p>bar</p>	<p>MIN: 1,5 MAX: 3,5</p>	
<p>28</p> 	<p>TYPE</p>	<p>HOLSET "4LGK"</p>	
<p>29</p> 	<p>G mm</p>	<p>0,30</p>	
	<p>G mm</p>	<p>0,30</p>	
<p>30</p> 	<p>A</p>	<p>68°</p>	
	<p>B</p>	<p>83°</p>	

	α \varnothing mm	$60^{\circ} 30' \pm 5'$ $10,892 \div 11,000$
	α \varnothing mm	$45^{\circ} 30' \pm 5'$ $10,892 \div 11,000$

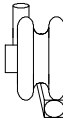
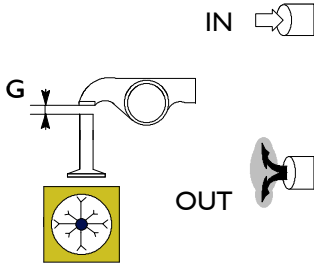
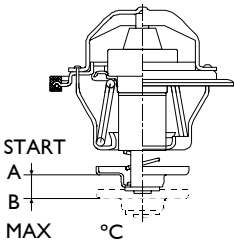
	α \varnothing mm	$60^{\circ} \pm 15'$ $59,080 \div 59,105$
	α \varnothing mm	$45^{\circ} \pm 15'$ $50,900 \div 50,930$

	X mm	$1,4 \div 1,8$
	X mm	$1,3 \div 1,9$

	$\varnothing 1$ mm	$11,025 \div 11,045$
	$\varnothing 2$ mm	$18,030 \div 18,005$

	mm	$0,010 \div 0,053$
--	-------------	--------------------

	H mm	$7,921$
	H mm	8

	G mm	$—$
	G mm	$—$

	H mm	$—$
	$\text{mm } 0,05$	$—$

	A	16°
	B	40°
	C	58°
	D	18°

	G mm	$0,30$
	G mm	$0,40$

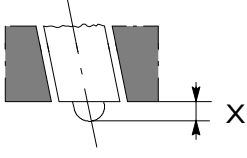
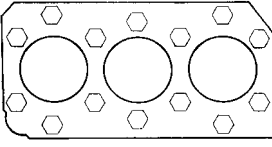
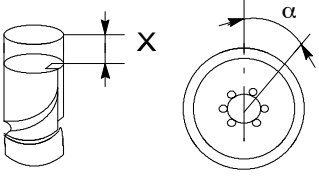
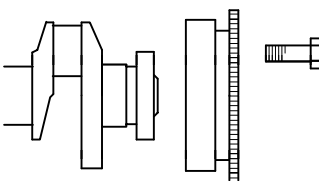
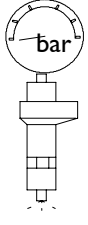
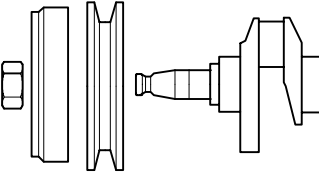
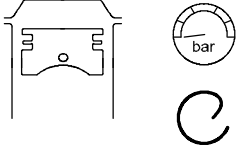
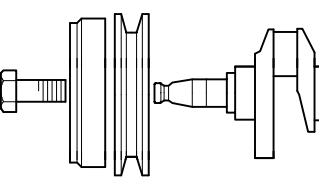
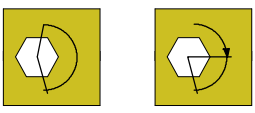
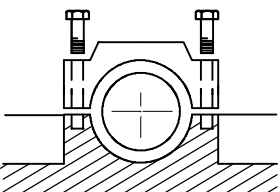
<p>41</p> 	<p>X mm</p>	<p>1,5 ÷ 2</p>	<p>46</p> 	<p>Nm Nm α α</p>	<p>1st STEP 200 2nd STEP 200 3rd STEP 120° 4th STEP —</p>
<p>42</p> 	<p>X mm</p>	<p>3,335 ÷ 3,45</p>	<p>47</p> 	<p>Nm</p>	<p>1st STEP 102</p>
	<p>α</p>	<p>19° ± 1°</p>		<p>α</p>	<p>2nd STEP 60°</p>
<p>43</p> 	<p>bar</p>	<p>250 + 8</p>	<p>48</p> 	<p>Nm</p>	<p>931</p>
<p>44</p> 	<p>bar</p>	<p>19</p>	<p>49</p> 	<p>Nm</p>	<p>1st STEP —</p>
	<p>RPM</p>	<p>275</p>		<p>α</p>	<p>2nd STEP —</p>
<p>45</p> 	<p>Nm</p>	<p>—</p>	<p>50</p> 	<p>Nm</p>	<p>1st STEP 412</p>
	<p>α</p>	<p>—</p>		<p>α</p>	<p>2nd STEP —</p>

ENGINE TYPE

8210SRM36 / 10 / 11

8210SRM36.30 / 31

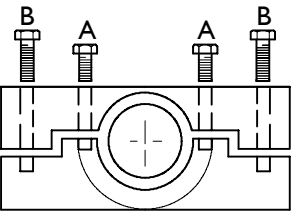

51 	Nm	1 st STEP —
	α	2 nd STEP —

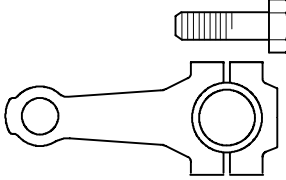
52 	Nm	1 st STEP 275
	α	2 nd STEP —

NOTES: