

8210SRi26.00

8210SRi26.01

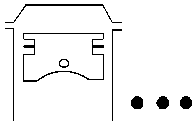

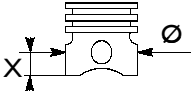
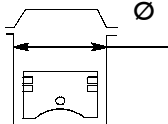
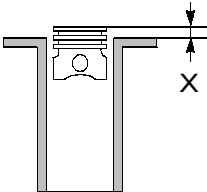
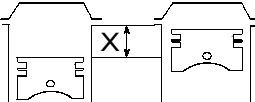
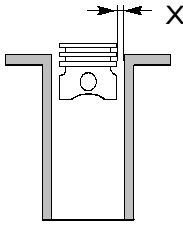
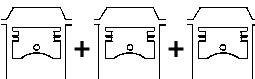
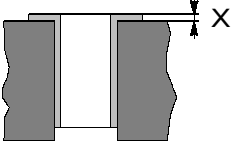
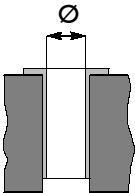
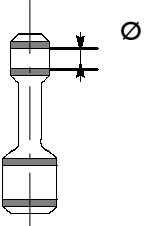
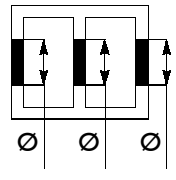
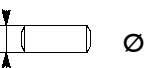
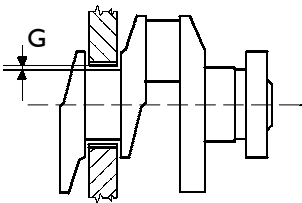
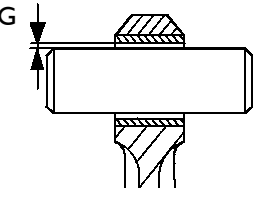
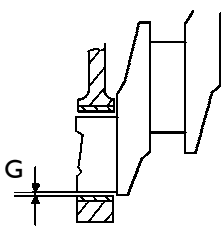
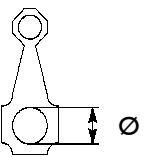
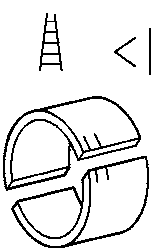
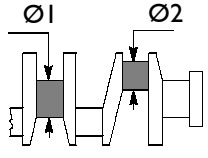
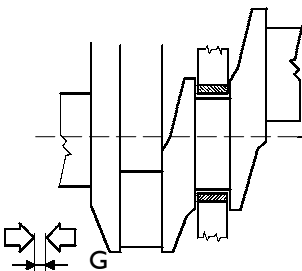

<p>1</p> 	Q.ty	6	<p>6</p> 	X mm	33
<p>2</p> 	Ø mm	137	<p>7</p> 	X mm	$136,813 \div 136,827$ CLASS A $136,848 \div 136,862$ CLASS B
<p>3</p> 	X mm	156	<p>8</p> 	X mm	$0,128 \div 0,177$
<p>4</p> 	cm ³	13798	<p>9</p> 	X mm	$0 \div +0,065$
<p>5</p> <p>Ø</p>		15 : 1	<p>10</p> 	Ø mm	$136,955 \div 136,990$ CLASS A $136,990 \div 137,025$ CLASS B

<p>11</p> 	<p>Ø 1 mm</p>	<p>50,019 ÷ 50,035</p>	<p>16</p> 	<p>Ø 1 mm</p>	<p>107,976 ÷ 108,001</p>
<p>12</p> 	<p>Ø 1 mm</p>	<p>49,995 ÷ 50,000</p>	<p>17</p> 	<p>G mm</p>	<p>0,083 ÷ 0,148</p>
<p>13</p> 	<p>G mm</p>	<p>0,019 ÷ 0,040</p>	<p>18</p> 	<p>G mm</p>	<p>0,051 ÷ 0,139</p>
<p>14</p> 	<p>Ø mm</p>	<p>88,482 ÷ 88,504</p>	<p>19</p> 	<p>mm</p>	<p>- 0,254 - 0,508 - 0,762 - 1,016</p>
<p>15</p> 	<p>Ø 1 mm</p>	<p>102,874 ÷ 102,901</p>	<p>20</p> 	<p>G mm</p>	<p>0,056 ÷ 0,328</p>
<p></p>	<p>Ø 2 mm</p>	<p>84,708 ÷ 84,735</p>	<p></p>	<p></p>	<p></p>

8210SRi26.00

8210SRi26.01

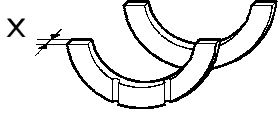
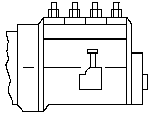
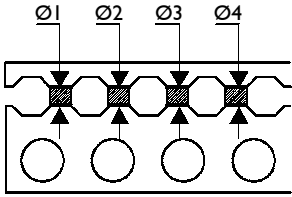

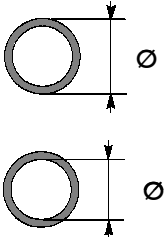
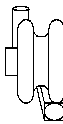
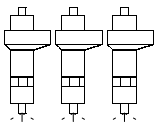
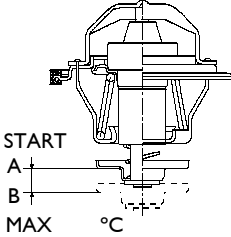
<p>21</p> 	<p>X mm</p>	<p>2,311 ÷ 2,362</p>		<p>26</p> 	<p>I.P.</p>	<p>PE 6P 120A</p>
<p>22</p> 	<p>mm</p>	<p>Ø1</p>	<p>68,515 ÷ 68,550</p>	<p>27</p> <p>OIL PRESSURE</p> 	<p>REG.</p>	<p>ELECTRONIC "WOODWARD"</p>
	<p>mm</p>	<p>Ø2</p>	<p>68,015 ÷ 68,050</p>		<p>bar</p>	
	<p>mm</p>	<p>Ø3</p>	<p>67,515 ÷ 67,550</p>			
	<p>mm</p>	<p>Ø4</p>	<p>67,015 ÷ 67,050</p>			
<p>23</p> 	<p>mm</p>	<p>Ø1</p>	<p>68,618 ÷ 68,669</p>	<p>28</p> 	<p>TYPE</p>	<p>HOLSET "H2D"</p>
	<p>mm</p>	<p>Ø2</p>	<p>68,135 ÷ 68,186</p>			
	<p>mm</p>	<p>Ø3</p>	<p>67,627 ÷ 67,678</p>			
	<p>mm</p>	<p>Ø4</p>	<p>67,119 ÷ 67,170</p>			
	<p>mm</p>	<p>Ø1</p>	<p>62,599 ÷ 62,660</p>			
	<p>mm</p>	<p>Ø2</p>	<p>62,099 ÷ 62,160</p>			
	<p>mm</p>	<p>Ø3</p>	<p>61,600 ÷ 61,661</p>			
	<p>mm</p>	<p>Ø4</p>	<p>61,100 ÷ 61,160</p>			
	<p>mm</p>	<p>Ø1</p>	<p>62,500 ÷ 62,530</p>			
	<p>mm</p>	<p>Ø2</p>	<p>62,000 ÷ 62,030</p>			
	<p>mm</p>	<p>Ø3</p>	<p>61,500 ÷ 61,530</p>			
	<p>mm</p>	<p>Ø4</p>	<p>61,000 ÷ 61,030</p>			
<p>25</p> 	<p>ORDER</p>	<p>1 - 5 - 3 - 6 - 2 - 4</p>		<p>30</p> 	<p>A</p>	<p>68°</p>
					<p>B</p>	<p>83°</p>

31 	α \varnothing mm $60^{\circ} 30' \pm 5'$ $10,892 \div 11,000$		H mm	7,92 I		
	α \varnothing mm $45^{\circ} 30' \pm 5'$ $10,892 \div 11,000$		H mm	8		
32 	α \varnothing mm $60^{\circ} \pm 15'$ $59,080 \div 59,105$		G mm	—		
	α \varnothing mm $45^{\circ} \pm 15'$ $50,900 \div 50,930$		G mm	—		
33 	X mm	1,4 ÷ 1,8				
	X mm	1,3 ÷ 1,9			H mm	—
34 	$\varnothing 1$ mm $11,025 \div 11,045$		A	16°		
	$\varnothing 2$ mm $18,030 \div 18,005$		B	40°		
35 	mm	0,010 ÷ 0,053	C	58°		
			D	18°		
			36 		G mm	0,30
					G mm	0,40
37 			A	16°		
			B	40°		
			C	58°		
			D	18°		
38 			G mm	0,30		
			G mm	0,40		
39 			G mm	0,30		
			G mm	0,40		
40 			G mm	0,30		
			G mm	0,40		

8210SRi26.00

8210SRi26.01

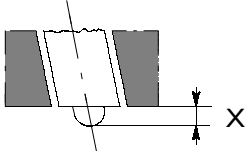
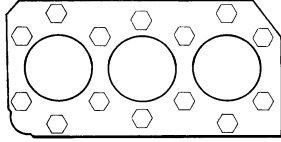
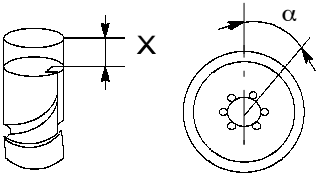
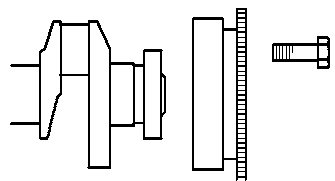
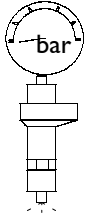
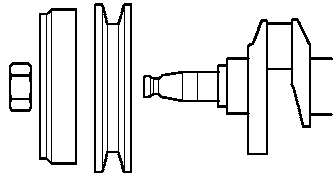
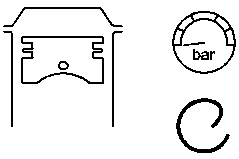
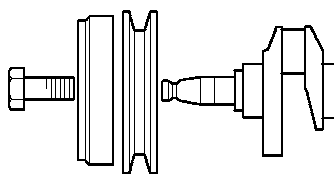
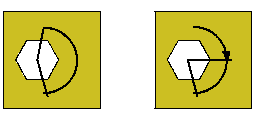
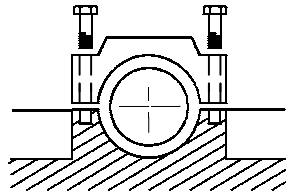

<p>41</p> 	<p>X mm</p>	<p>1,5 ÷ 2</p>	<p>46</p> 	<p>Nm Nm α α</p>	<p>1st STEP 200 2nd STEP 200 3rd STEP 120° 4th STEP —</p>
<p>42</p> 	<p>X mm</p>	<p>3,5 ÷ 3,6</p>	<p>47</p> 	<p>Nm</p>	<p>1st STEP 102</p>
<p>α</p>	<p>α</p>	<p>22° ± 1°</p>	<p>α</p>	<p>α</p>	<p>2nd STEP 60°</p>
<p>43</p> 	<p>bar</p>	<p>250 + 8</p>	<p>48</p> 	<p>Nm</p>	<p>931</p>
<p>44</p> 	<p>bar</p>	<p>19</p>	<p>49</p> 	<p>Nm</p>	<p>1st STEP —</p>
<p>e RPM</p>	<p>e</p>	<p>275</p>	<p>α</p>	<p>α</p>	<p>2nd STEP —</p>
<p>45</p>  <p>Nm α</p>	<p>Nm</p>	<p>—</p>	<p>50</p> 	<p>Nm</p>	<p>1st STEP 412</p>
<p>α</p>	<p>α</p>	<p>—</p>	<p>α</p>	<p>α</p>	<p>2nd STEP —</p>

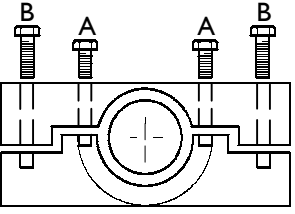
<p>51</p> 	Nm	1 st STEP —
	α	2 nd STEP —

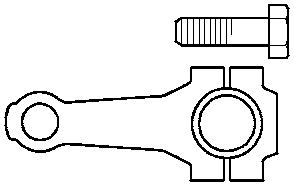
<p>52</p> 	Nm	1 st STEP 275
	α	2 nd STEP —

NOTES: